

Brake Caliper HS 120 HFK

hydraulically activated – spring released
for wind turbines or conveyor systems

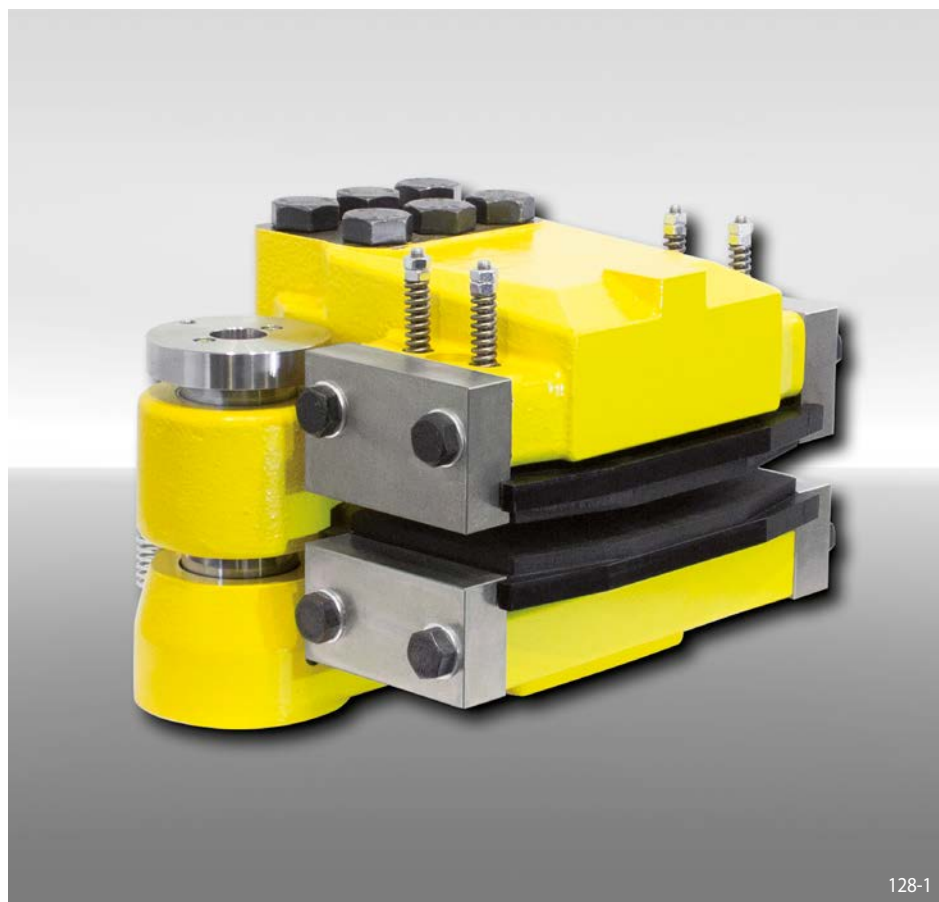

Features	Code
Brake Caliper	H
Floating caliper	S
Frame size 120	120
Hydraulically activated	H
Spring released	F
No adjustment to accommodate friction block wear	K
Max. clamping force 130 kN	130

Example for ordering

Brake Caliper HS 120 HFK, max. clamping force 130 kN:

HS 120 HFK - 130

Technical Data

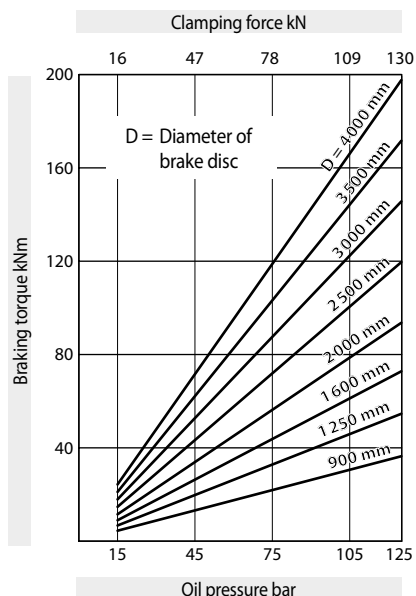

The braking torques shown in the diagram are based on a theoretical friction coefficient of 0,4.

Oil pressure: min. 15 bar
max. 125 bar

Oil volume: max. 203 cm³

Weight: ca. 195 kg

Other features

- High safety against leakage
- Easy change of friction blocks
- Painted with surface coating class C4-L according to ISO 12944
- For brake disc thickness $W = 20$ mm; brake disc thicknesses of up to 40 mm can be achieved with the use of a spacer installed by the customer

Accessories

- Inductive proximity switch for "brake released" operating status
- Inductive proximity switch for brake pad wear control
- Optional painting with surface coating class C4-H or C5M-H (offshore) according to ISO 12944

Brake Caliper HS 120 HFK

hydraulically activated – spring released
for wind turbines or conveyor systems

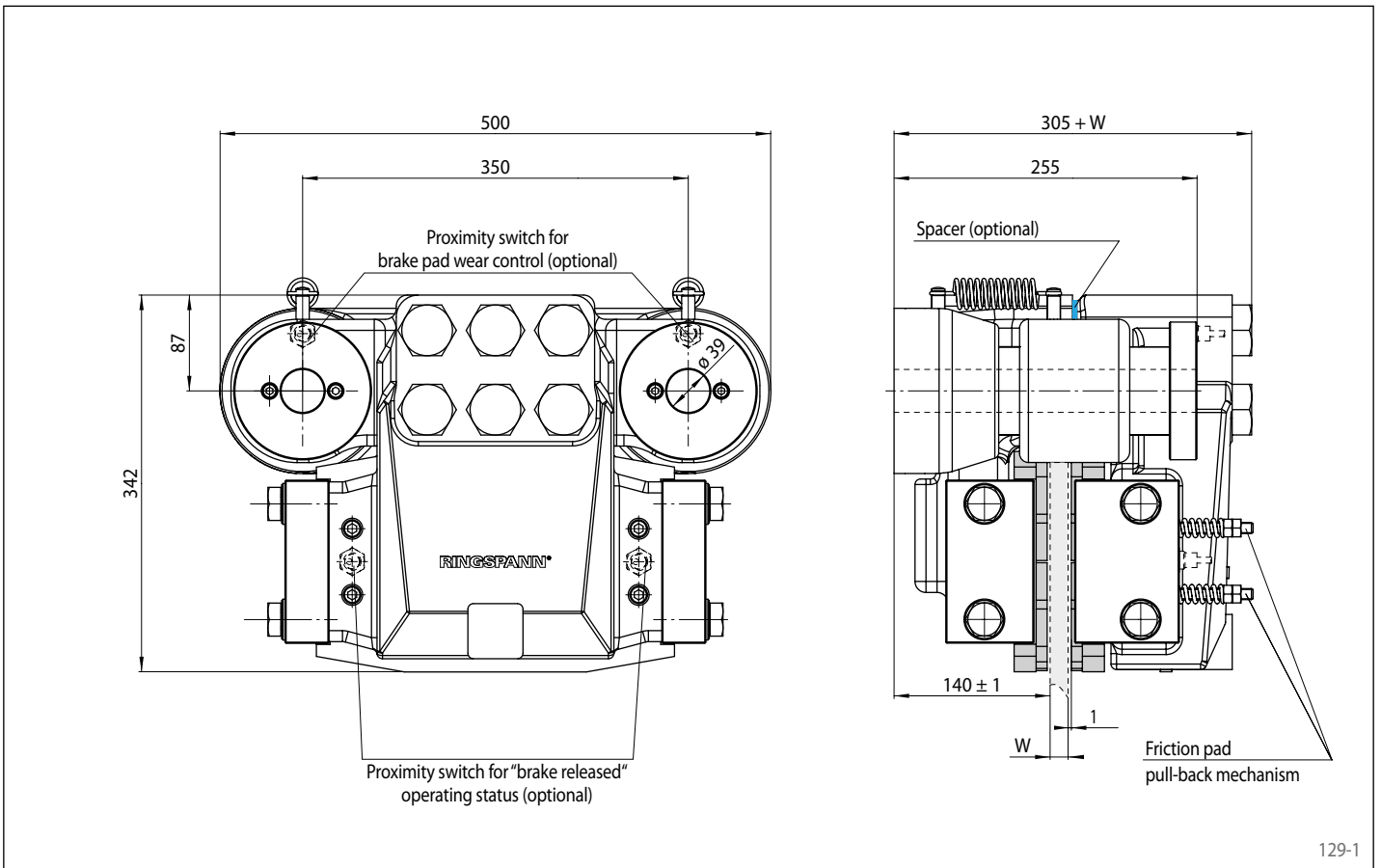

129-1

Mounting

